

Stručnjaci u opskrbi energijom



**Regulator tlaka plina
Gas pressure regulator
EKB-SMART FLOW 40/50/75
EKB-SF**



The Experts in Energy Supply

EKB-SMART FLOW EKB-SF

DVOSTUPANJSKI REGULATOR TLAKA PLINA

TWO STAGE PRESSURE REGULATOR

EKB-SMART FLOW se primjenjuje za opskrbu plinom općina, domaćinstava, industrijskih i komunalnih potrošača i plamenika u kotlovnica.

Već standardno je dvostupanjski regulator tlaka plina opremljen sigurnosnim zapornim ventilom. Na raspolaganju su različite mogućnosti priključivanja i izvedbi; sa ili bez prirubnica, vanjskim ili unutarnjim navojima, ravni ili kutni, sa osiguračem od nestanka plina, sigurnosnim ispusnim ventilom i uređajem za ograničenje stope protoka.

Regulator tlaka plina je proizveden u skladu sa PED 2014/68/EU, EN334 standardima.

The EKB-SMART FLOW is used for gas supply of municipalities and industry as houses, communal facilities, big flats thru process gas supply for burner in boiler houses.

As standard, the two stage gas pressure regulators are fitted with a safety shut-off valve. A range of connectors and designs with or without flanges, internal or external threaded, inline or corner version, pressure cut-off for supply, interruption protection, safety blow-off valve and flow rate limitation devices are available.

The gas pressure regulator is designed according to PED 2014/68/EU, EN334.

TEHNIČKI PODACI

TECHNICAL DATA

Dopušteni ulazni tlak:	0,06 ÷ 10,0 bar
Nazivna dimenzija:	½"/¾" DN 25/40/50
Područje izlaznog tlaka:	pas 20 ÷ 300mbar
Postavljene vrijednosti sigurnosnog zapornog ventila:	
pso	30 ÷ 400 mbar
psu	15 ÷ 200 mbar
Regulatorna grupa:	AC 5/10
Grupa zatvaranja:	SG 20/30
Točnost:	pso/psu AGo 10/AGu 30
Stopa protoka:	vidi dijagram
Temperaturno područje:	-20/30 ÷ + 60 °C
Položaj ugradnje:	proizvoljan
Priključci:	prirubnice, unutarnji navoj, vanjski navoj

Perm.inlet pressure:	0,06 ÷ 10,0 bar
Nominal dimension:	½"/¾" DN 25/40/50
Outlet pressure range:	pas 20 ÷ 300mbar
Set range of safety shut-off valve:	
pso	30 ÷ 400 mbar
psu	15 ÷ 200 mbar
Regulatory class:	AC 5/10
Lock-up pressure class:	SG 20/30
Accuracy:	pso/psu AGo 10/AGu 30
Flow rate:	see diagram
Range of temperature:	-20/30 ÷ + 60 °C
Position of installation:	discretionary
Connection:	flange, internal threaded external threaded

MATERIJALI

MATERIALS

Regulator, SZV, kućište:	tlačno lijevani aluminij
Priključci ulazni-/izlazni:	pocinčani čelik
Unutarnji dijelovi:	čelik, mesing, plastika
Membrana:	perbunan (guma otporna na pentan)
O-prsten:	NBR, FPM

Regulator, SBV, body:	Die-casting aluminium
Connection inlet/outlet:	Zinc plated steel
Internals:	Steel, brass, plastic
Diaphram:	Perbunan (pentane resistant rubber)
O-Ring:	NBR, FPM

EKB-SMART FLOW EKB-SF

DIMENZIJE U MM

DIMENSIONS IN MM

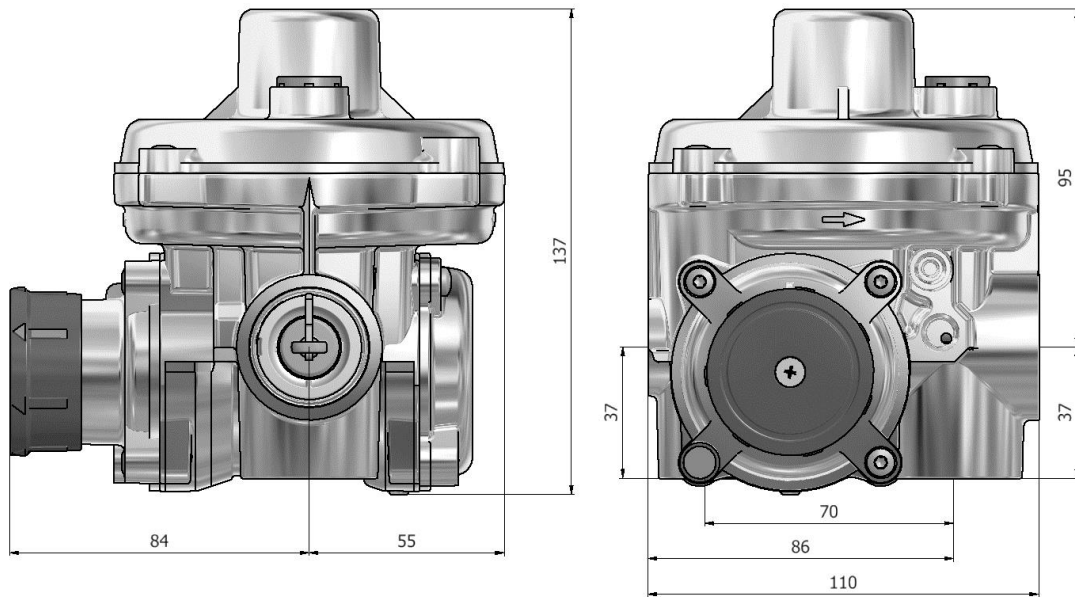

DIJAGRAM PROTOKA*

FLOW DIAGRAM*

EKB-SF-40

Pds=25mbar; AC5; SG20;

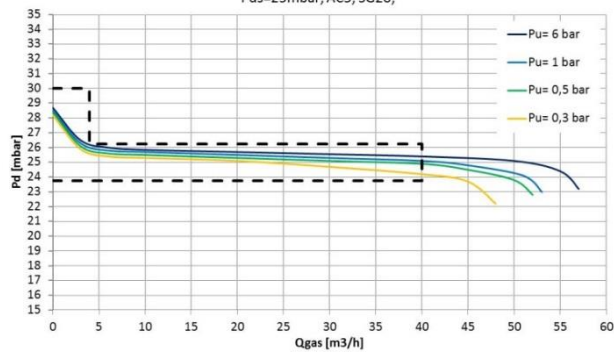

EKB-SF-50

Pds=25mbar; AC5; SG20;

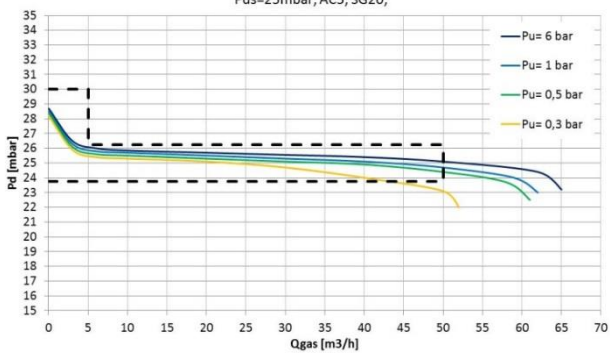

EKB-SF-75

Pds=25mbar; AC10; SG20;

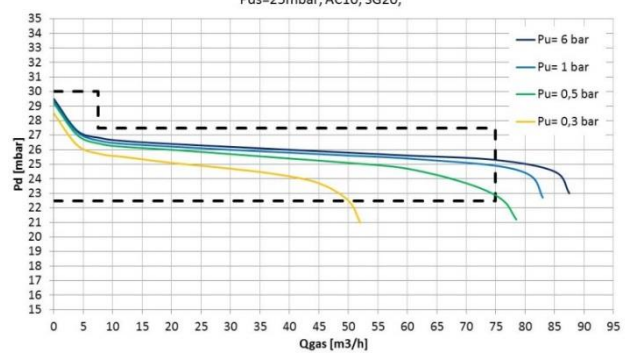

*(ovisno o postavci područja izlaznog tlaka na 2. stranici)

*(product to order according to the outlet pressure range on the 2. page)

